

# Breathe in to Boost Performance !

## HOW TRAINING THE INSPIRATORY MUSCLES CAN IMPROVE ROWING PERFORMANCE



PRODUCTS  
MILLENNIUM

**Rowers are amongst the most aerobically fit athletes in modern sport.** They are also amongst the largest - heavy-weight male rowers average over 1.90m (6'3") in height, weighing almost 90kg (14st), whilst the figures for heavy-weight women are 1.80m (5'11") and 73kg (11st 6lb). Rowing races normally take place on a straight course that is 2000m in length and last between 5½ and 7½ minutes (approximate Olympic records for the men's eight and women's single skull, respectively).

**During a race, breathing can reach maximal levels in excess of 250 litres per minute for a heavy-weight male rower - the average 'man in the street' would be hard pushed to achieve even half this value. With such a high demand placed upon breathing it is easy to see why rowing induces fatigue of the breathing muscles, even in international athletes.**

Rowing has more in common with swimming than the aquatic environment in which it takes place - both sports require the synchronisation of breathing and locomotion. This linkage pushes breathing to its limits. During a 2000m race, the athletes are breathing twice per stroke, they breathe out during the initial part of the drive (when the blade is in the water), take a breath as they reach the end of the drive, breathe out again as they come forward and take a small breath just before 'the catch'. This small breath at the catch is very important in terms of allowing the optimal transmission of force from the various body segments through the blade and into the water; the muscles of the torso to brace against a partially inflated lung.

Somehow our bodies 'know' that this strategy is optimal. For example, if you were going to lift a heavy object, you intuitively breathe in and brace yourself by contracting the muscles of your torso against your inflated lungs', explains sports scientists and respiratory physiologist Dr Alison McConnell. 'The muscles of the torso include your breathing muscles, and its pretty difficult to brace the upper body and breathe at the same time, so you have to work your breathing in around the stroke rate.'

**Alison is an expert on breathing during exercise and, whilst based at Birmingham University, her research team developed a training device that specifically targets the breathing muscles - POWERbreathe®.** You breathe through the portable, hand-held device for 30 repetitions (this takes 3 minutes) twice daily, and the strength of your inspiratory muscles increases by around 30-50%. McConnell's research team have also proved the ergogenic effect of the POWERbreathe in other sports, including cycling.

**Her ground-breaking research on POWERbreathe training has shown that it significantly improves rowing performance and helps to eliminate breathing fatigue.**

She said, 'The improvements that we see in rowing are staggering and have been confirmed in our work on cycling; a three and a half percent improvement in time trial performance is typical and very impressive for the standard of athlete that we worked with.'

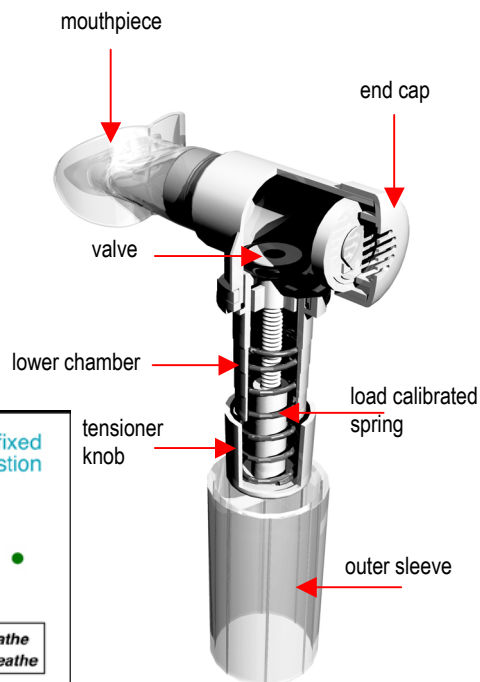
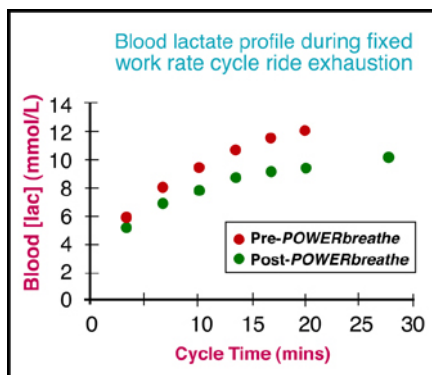
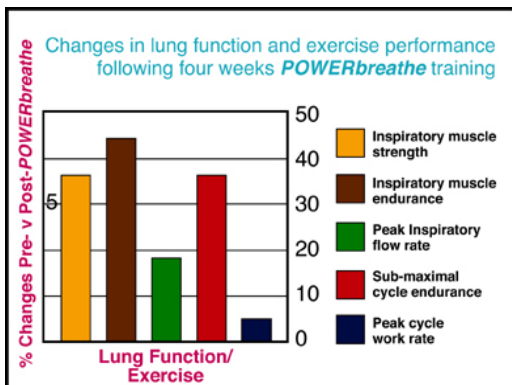

'As a result of my research I've been fortunate enough to work with international rowers both in the UK and Australia', explains Alison. 'I worked with the **Gold medal winning men's rowing eight in the build-up to the Sydney Olympics**, devising a tailor-made POWERbreathe programme to help ensure that their breathing was optimally prepared for their 2000m races. After I'd watched the Olympic final live on TV, I immediately emailed their coach, Martin McElroy, to congratulate them, he responded with the words that every sports scientists dreams of: he wrote **'thanks for all your help ...a slice of that gold belongs to you'.**'

POWERbreathe® is also used and endorsed by the GB Coxless Four (Richard Dunn, Ed Coode, Steve Williams, Toby Garbett) to give them an added 'boost' to their training. Richard Dunn, commented, ***"We are very pleased to secure this deal with POWERbreathe® – the product plays an important part in our training regime and it will give us an additional edge to our performance. The team's experience of POWERbreathe® has been very positive – it plays an integral role in our training and is particularly useful as a warm-up aid - I can really notice the difference if I row without having used it to warm-up with."***

The POWERbreathe is also a helpful addition to the warm-up preparations of athletes. Alison's research has shown that even a strenuous rowing warm-up fails to warm-up the breathing muscles, so her team developed a POWERbreathe warm-up routine that they've shown improves rowing performance significantly. By now you must be wondering just how much dedicated additional training is required to benefit from what POWERbreathe has to offer. **This is the really good news, the POWERbreathe training protocol can be done in the comfort of your arm chair and takes less than 3 minutes a day, with perceived results achieved in around 4 weeks!**

**For local stockists please call CHP on 01926 816177.**

**For mail order please call Bodycare on 01926 816155.**

For further press information, please contact Philippa Rawlinson on 01926 816118, or email [philippa.rawlinson@lsi.co.uk](mailto:philippa.rawlinson@lsi.co.uk)